

Einfamilienhaus

Detached house
Maison individuelle
Eengezinswoning

POLA G

Art. Nr. 331019



Sa. Nr. 331 019 1

- (D)**
- Verwenden Sie nur POLA G-Cement.
 - Machen Sie sich vor dem Zusammenbau gut mit den Einzelteilen des Bausatzes vertraut. Trennen Sie die Einzelteile erst dann ab, wenn sie gebraucht werden.
 - Verwenden Sie beim Zusammenbau wenig Klebstoff. Sie werden dann mehr Freude an einem sauberen Modell haben.
 - Sollte trotz werkseitiger sorgfältiger Prüfung ein Teil fehlen oder fehlerhaft sein, kreuzen Sie bitte das Teil in der Anleitung an und schicken Sie diese bitte an:
Gebr. FALLER GmbH, Abt. Kundendienst, kundendienst@faller.de, Kreuzstraße 9, D-78148 Gütenbach.
Sie erhalten dann umgehend Ersatz.

- Use POLA G-Cement only.
- (GB)**
- Familiarize yourself well with the components of the kit before assembly.
 - Do not break off the components until the moment you need them. Use glue sparingly on assembly, then you will enjoy your neat model even more.
 - If a part is missing or defective despite careful checking at the factory, please mark the part concerned in your instructions and send it to:
Gebr. FALLER GmbH, Abt. Kundendienst, kundendienst@faller.de, Kreuzstraße 9, D-78148 Gütenbach, Germany.
You will receive replacement promptly.

- N'utilisez que la colle POLA G -Cement.
- (F)**
- Avant l'assemblage, familiarisez vous avec les différentes pièces du jeu de construction.
 - Ne séparer les pièces particulières qu'au moment de les utiliser. Utiliser aussi peu de colle que possible pour l'assemblage, vous aurez d'autant plus de plaisir avec un modèle propre.
 - Si, malgré un contrôle soigneux à l'usine, une pièce devait manquer ou être défectueuse, marquer cette pièce d'une croix dans les instructions et envoyer ces dernières à:
Gebr. FALLER GmbH, Abt. Kundendienst, kundendienst@faller.de, Kreuzstraße 9, D-78148 Gütenbach (R.F.A.).
On vous la remplacera aussitôt.

- (NL)**
- Gebruik uitsluitend POLA G -cement.
 - Zorg da u vóór de montage goed weet uit welke onderdelen het bouw pakket bestaat. Maak de onderdelen pas los als u ze gaat gebruiken.
 - Gebruik bij de montage slechts weinig lijm. U zult dan meer plezier beleven aan een schoon model.
 - Mist u ondanks zorgvuldige fabrikantencontrole toch een onderdeel of is een onderdeel beschadigd, kruis dan het desbetreffende onderdeel aan in de handleiding en stuur dit s.v.p. aan:
Gebr. FALLER GmbH, Abt. Kundendienst, kundendienst@faller.de, Kreuzstraße 9, D-78148 Gütenbach, Duitsland.
Het wordt dan direct vervangen en naar u opgestuurd.





01

01-01

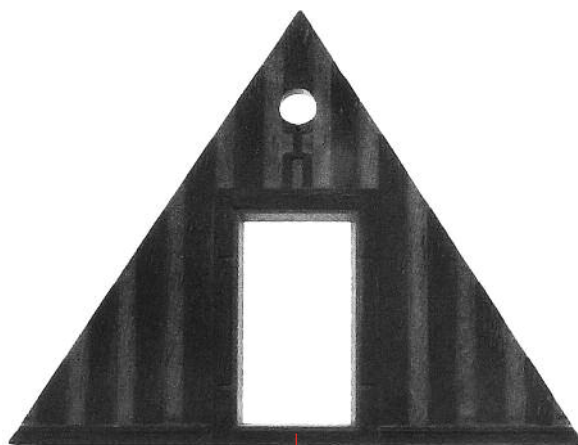

02

02-01

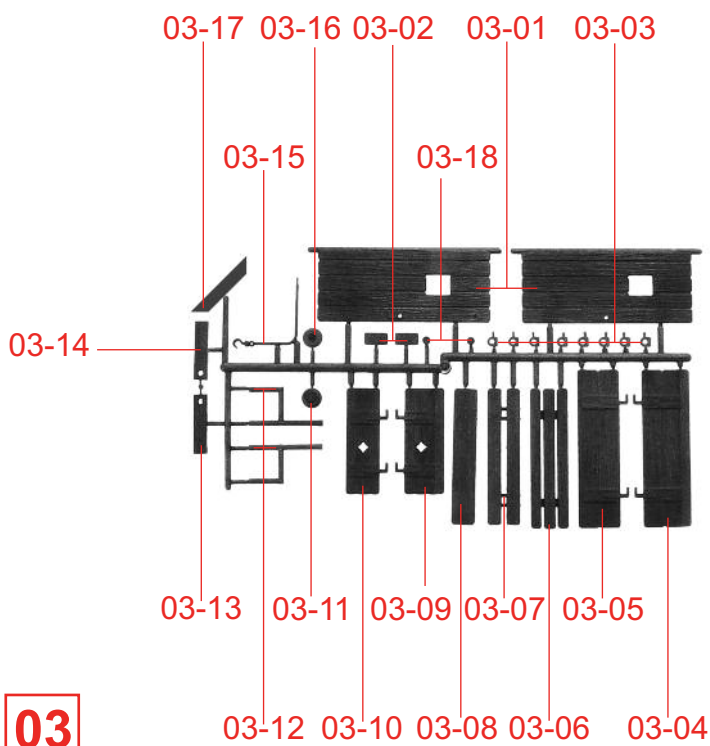

03

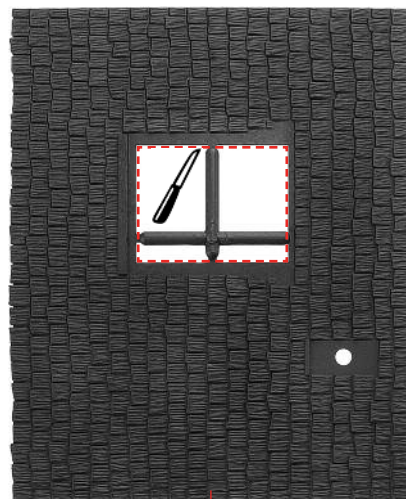

04 2 x

04-01

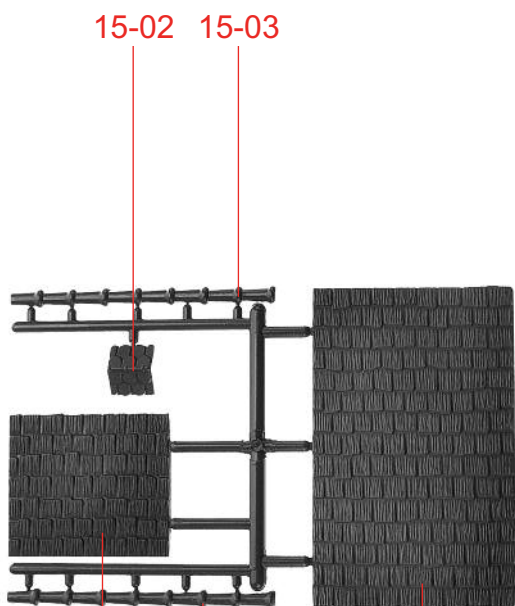

15

15-01 15-03

15-04

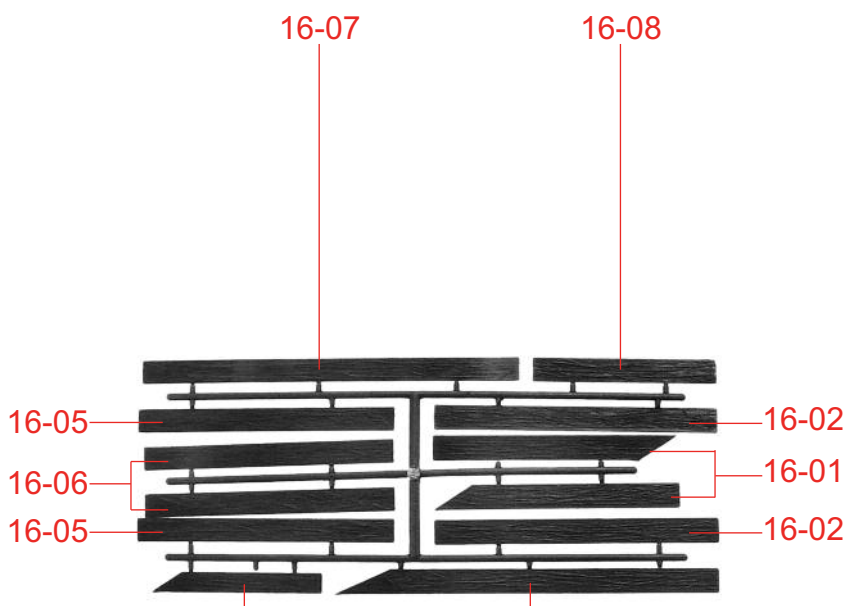

16 2 x

16-04

16-03



17

17-01

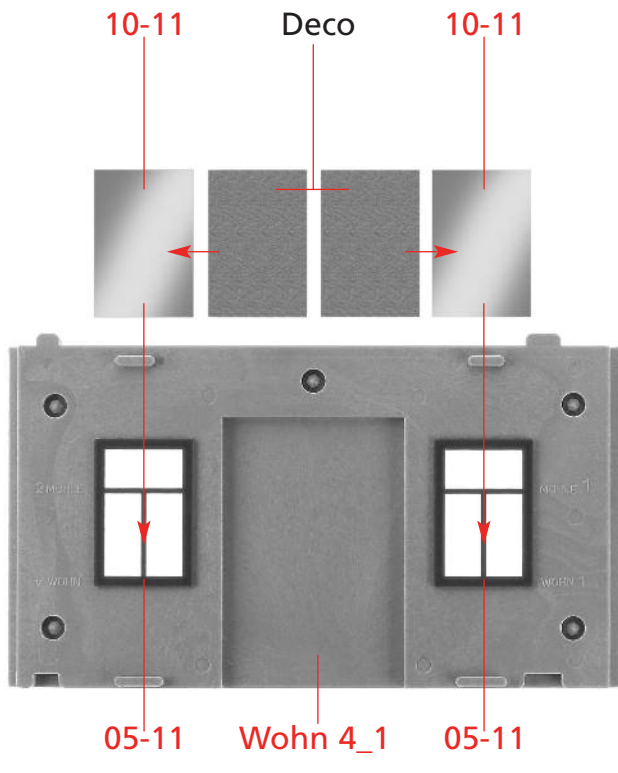

(A)

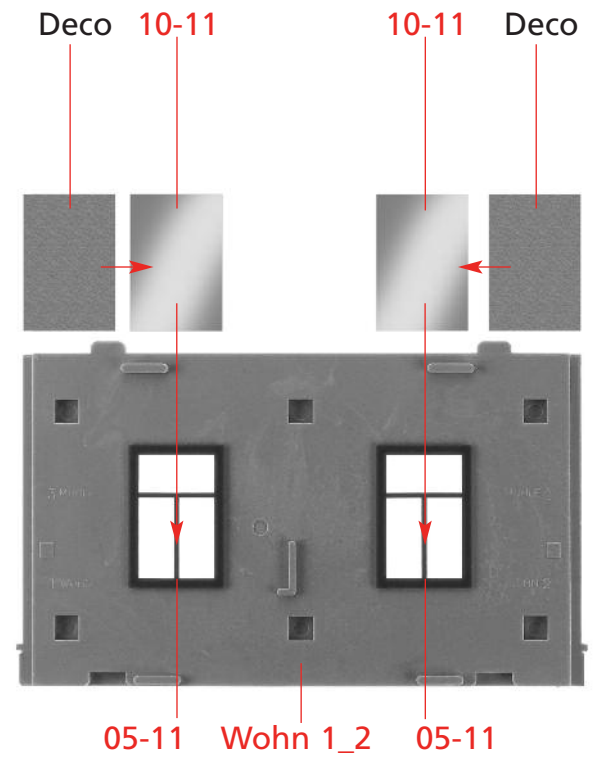

(B)

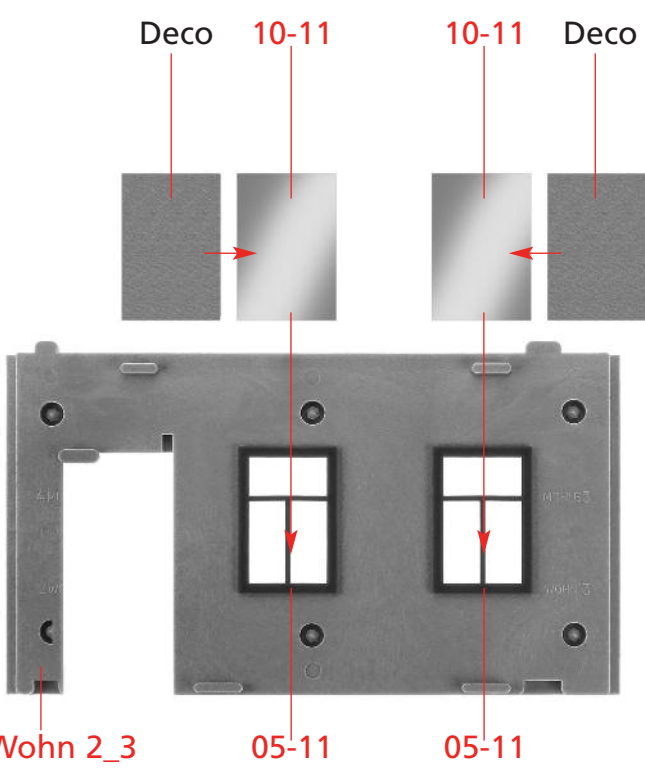

(C)

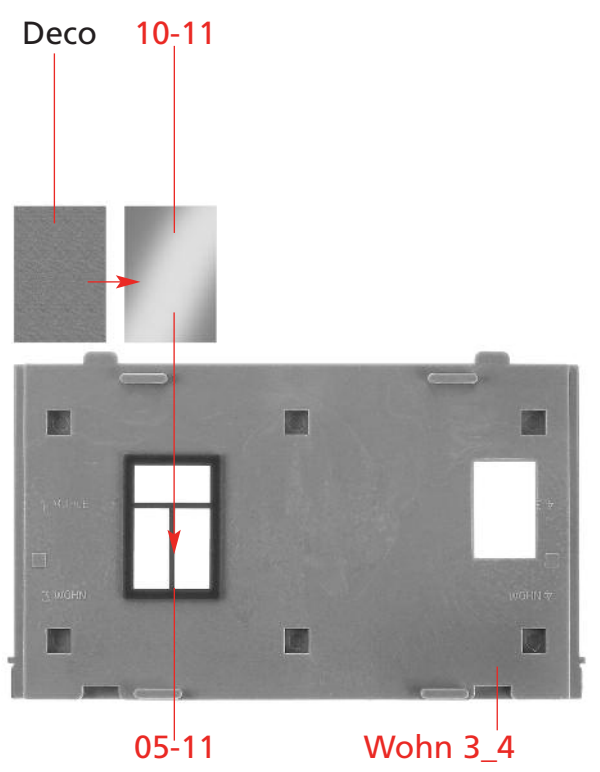

(D)

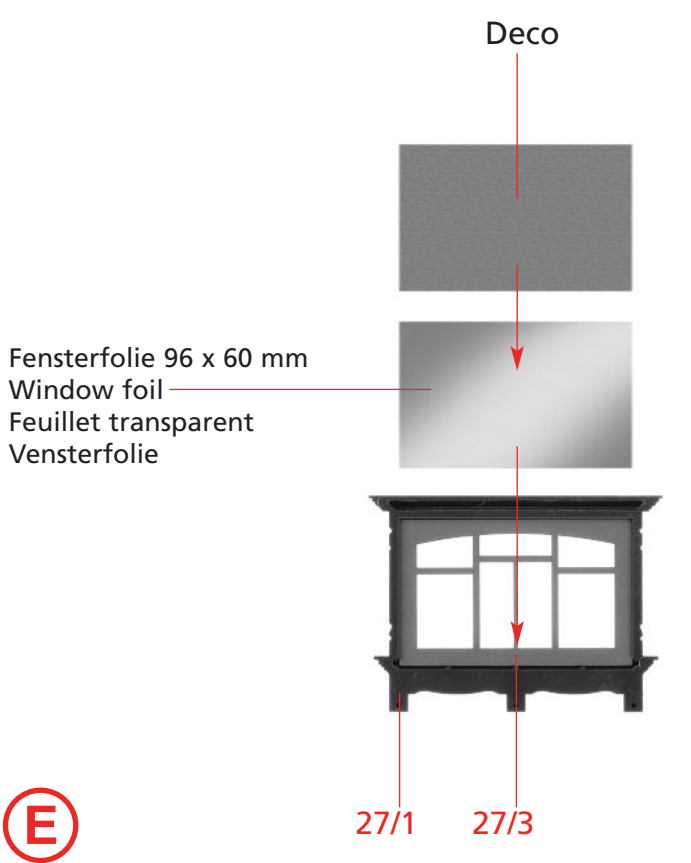

(E)

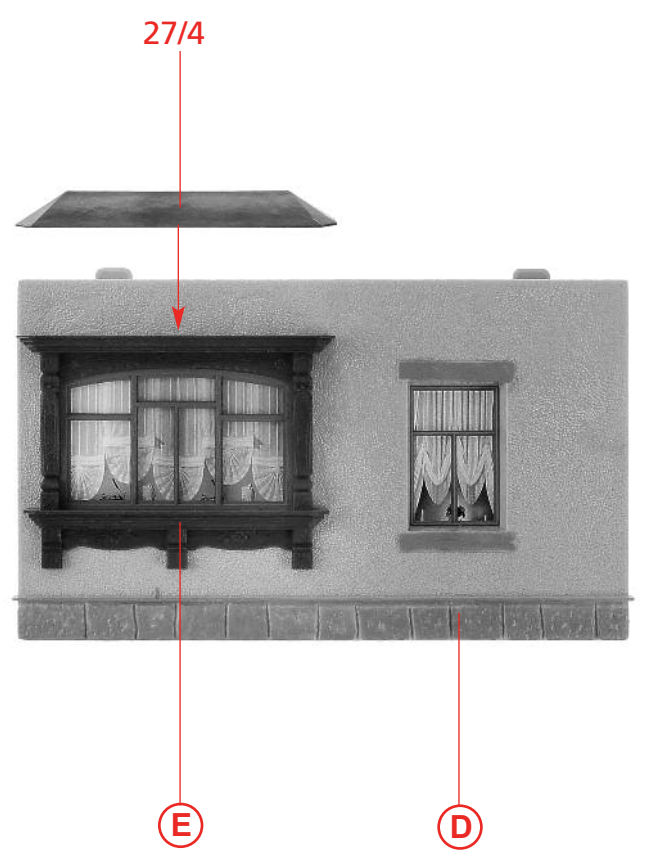

(F)

4

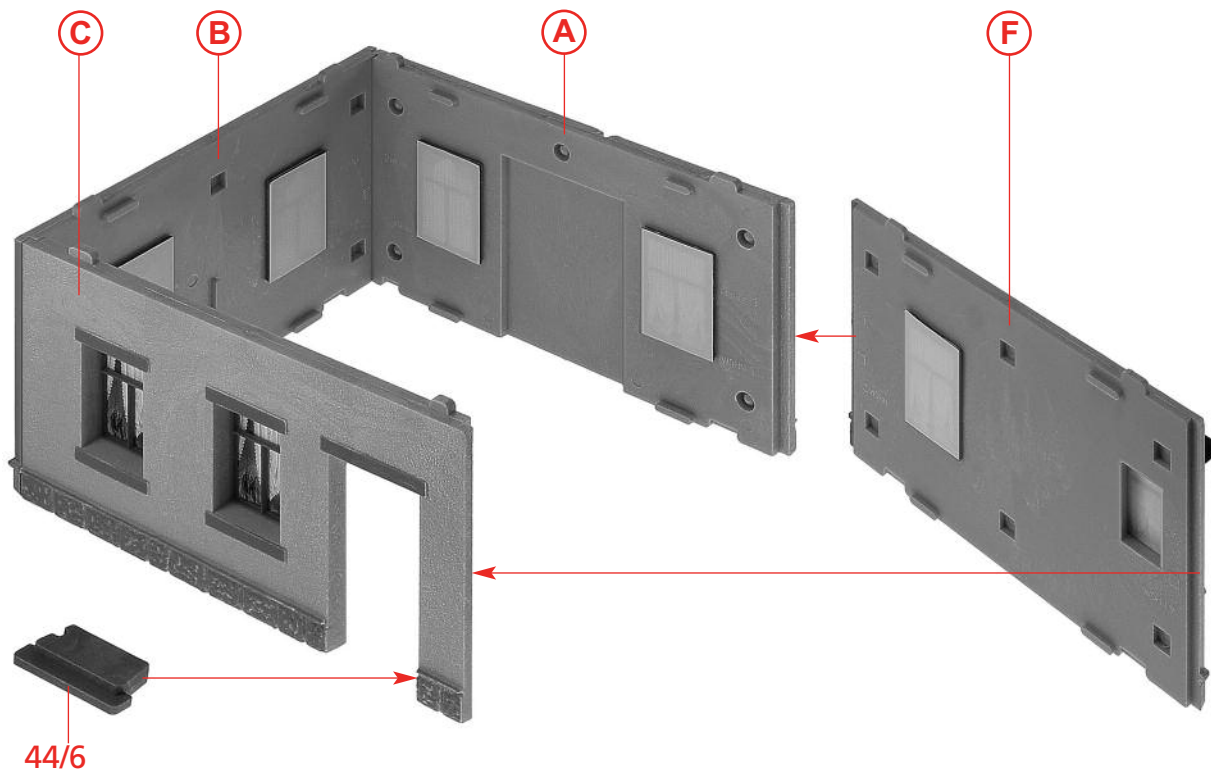

G

44/6

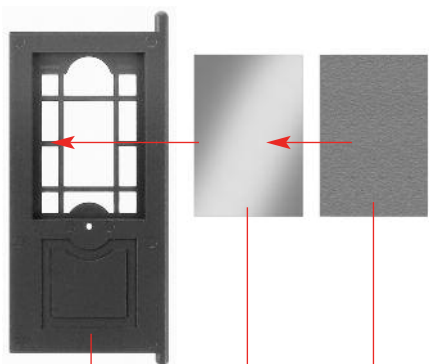

44/1

10-15

Deco

H

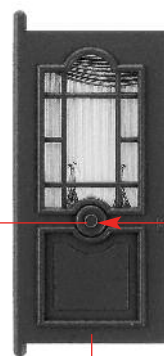

44/7

44/3

I

H

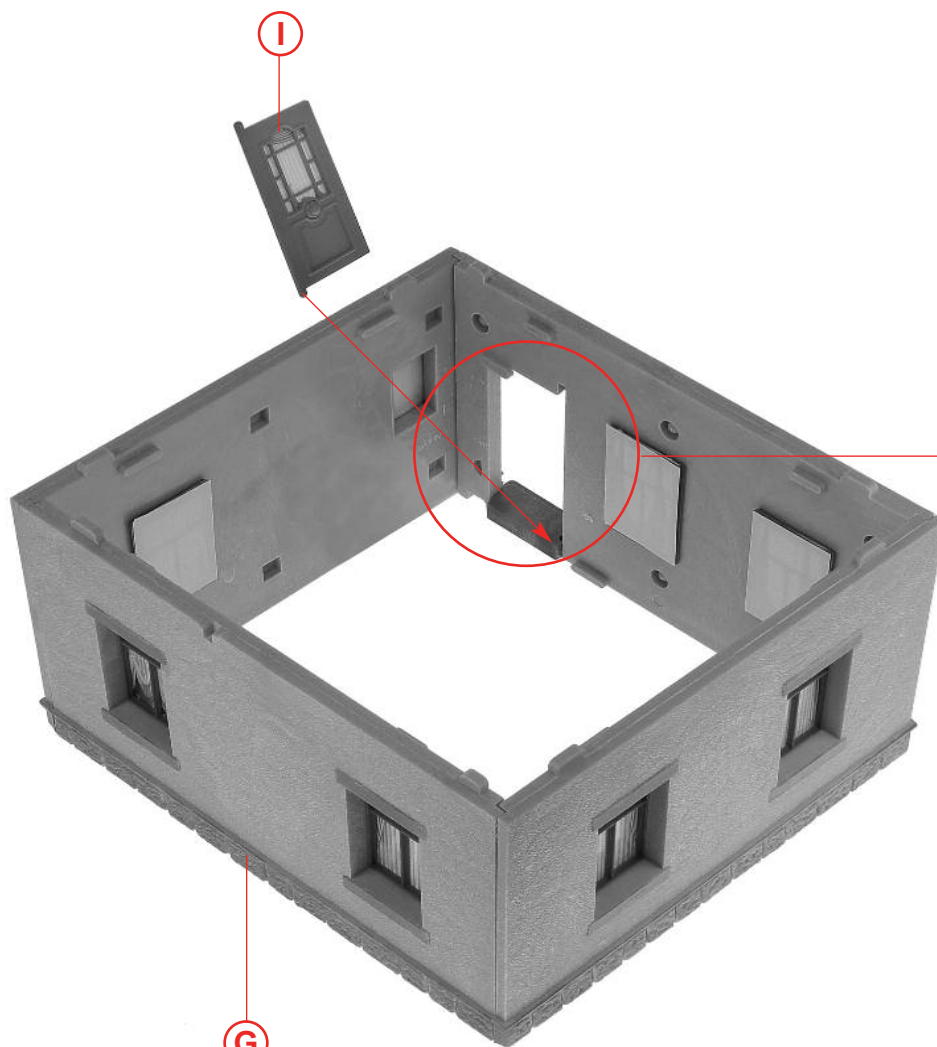

44/4

nicht kleben
do not glue
ne pas coller
niet lijmen

J

G

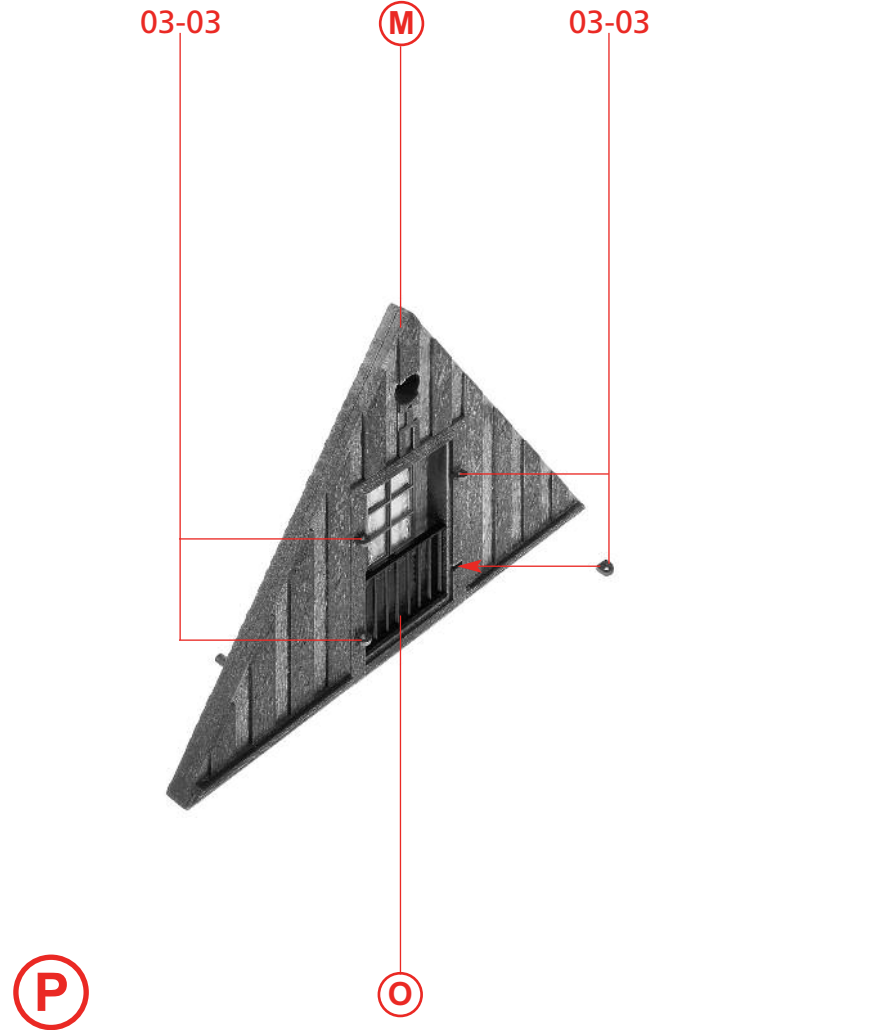
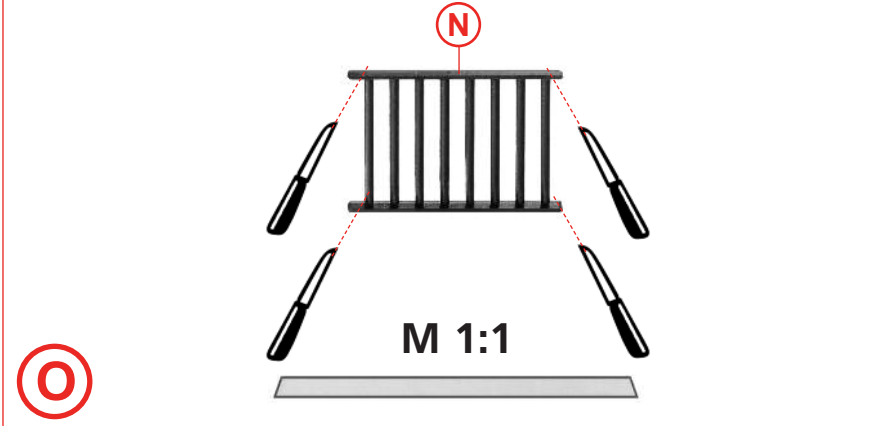
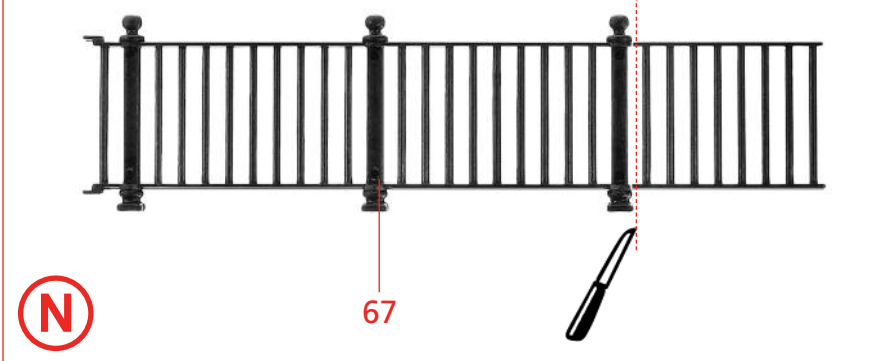
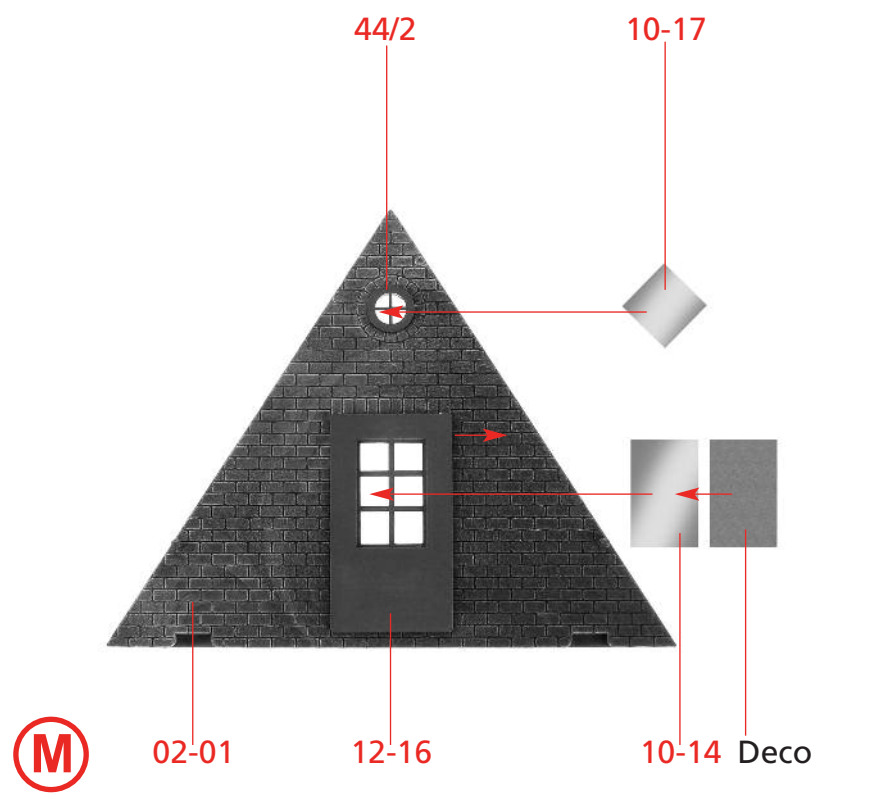
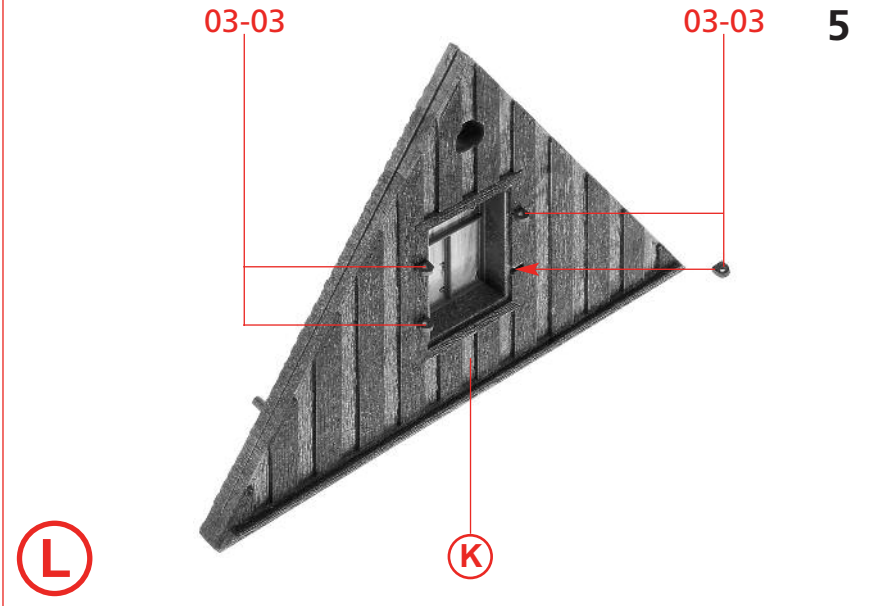
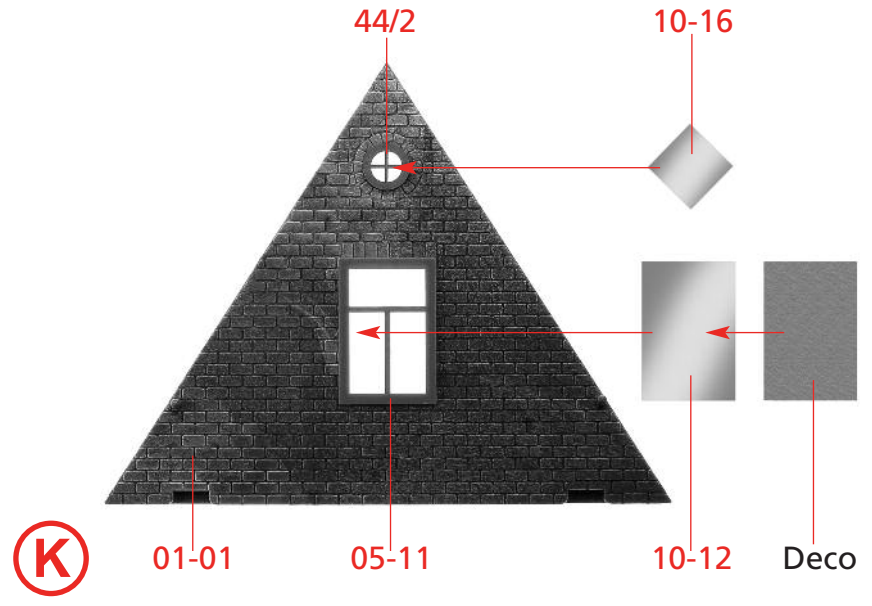

6

Deco

10-13

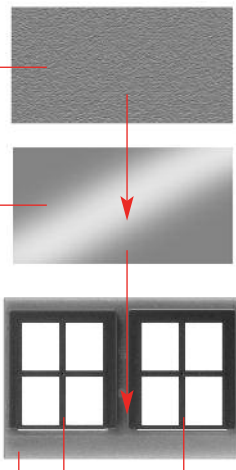

(R) 2 x

13-16 05-13

13-17

13-15

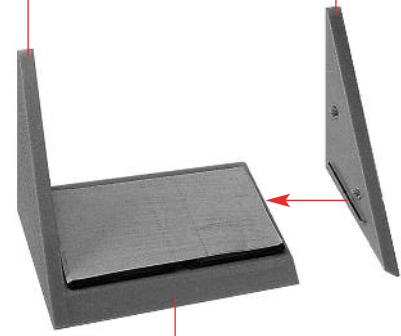

(S) 2 x

(R)

(S)

15-01

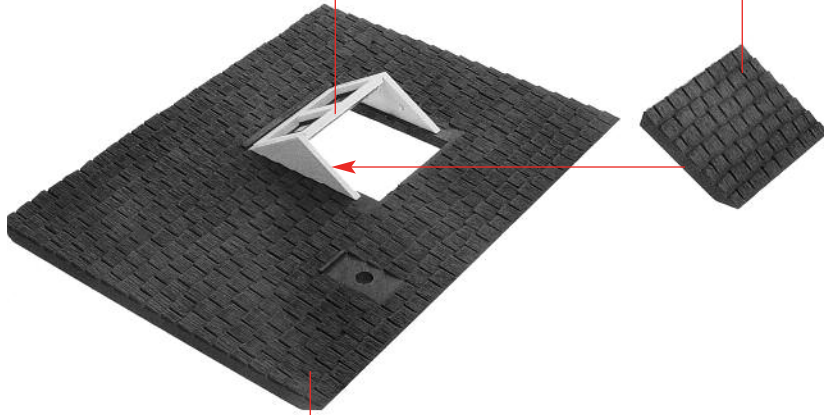

(T) 2 x

04-01

(T)

03-05

03-04

(T)

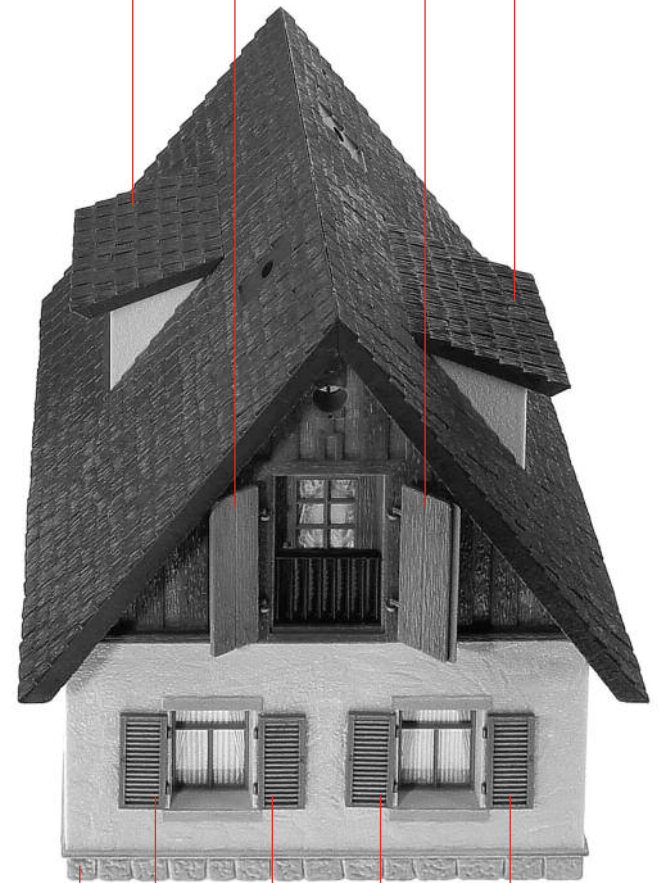

(U)

(Q)

07-12

07-11

07-12

07-11

13-12

13-18

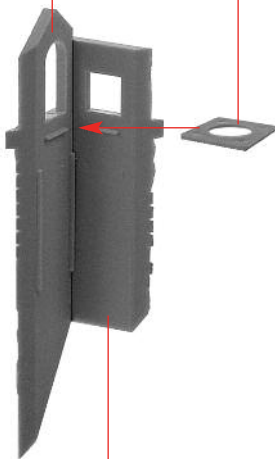

(V) 2 x

13-14

13-11

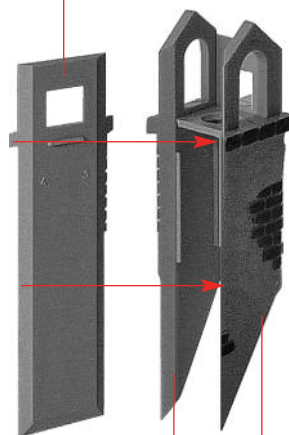

(W) 2 x

(V) 13-13

16-04

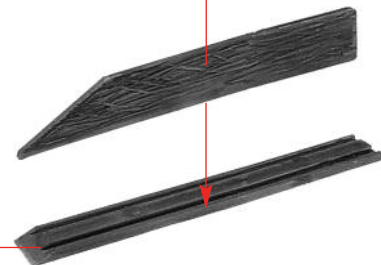

(X)

16-08

16-04

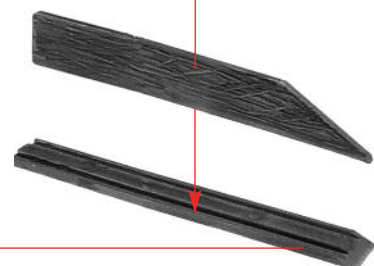

(Y)

16-08

a 2 x

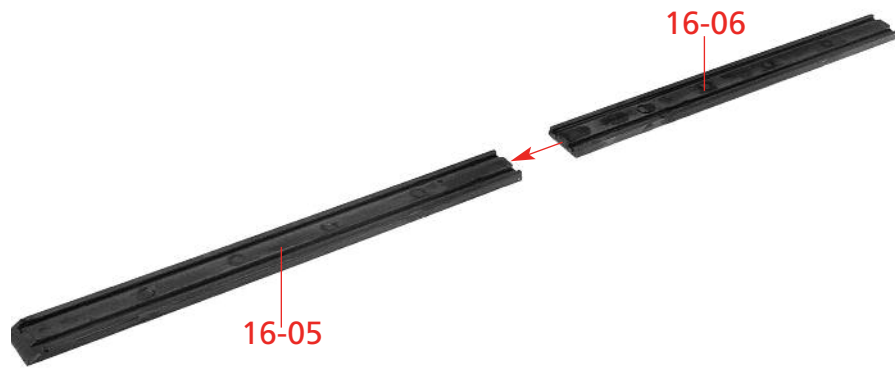

a

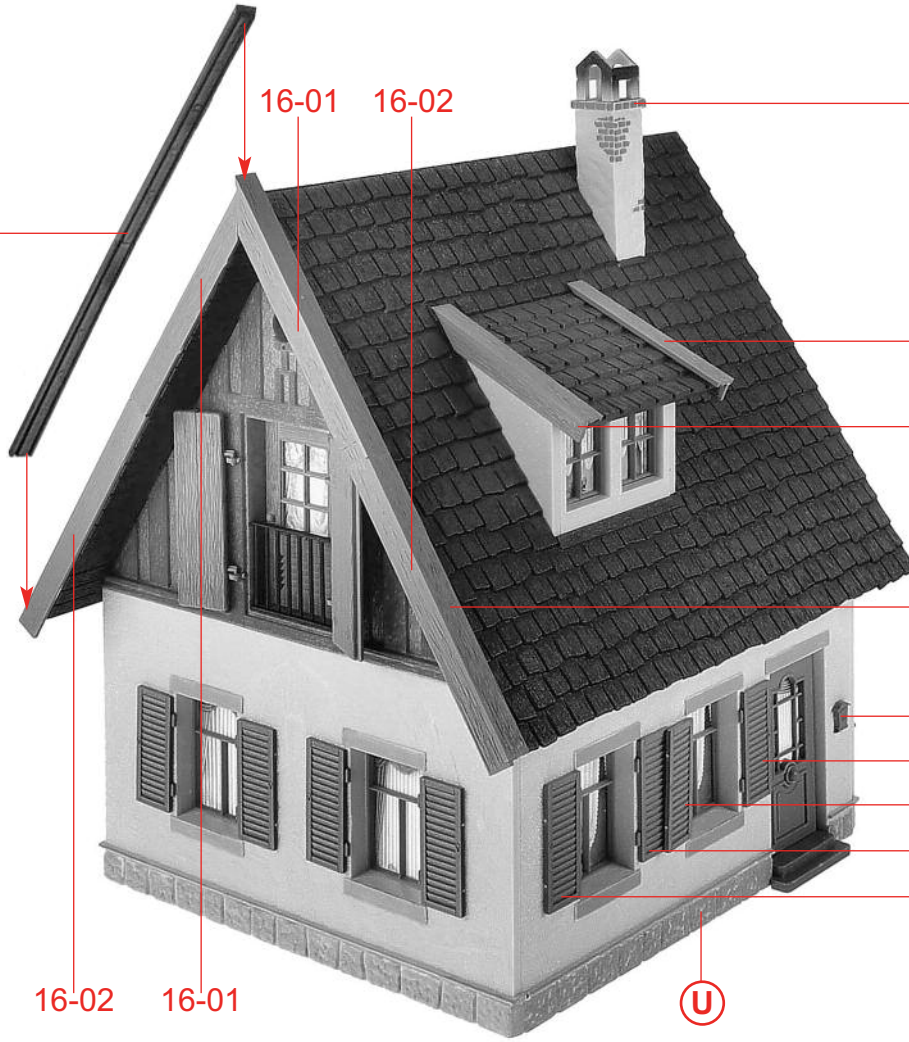

W

X

Y

a

44/5

07-11

07-12

07-11

07-12

b

16-02 16-01

U

c 2 x

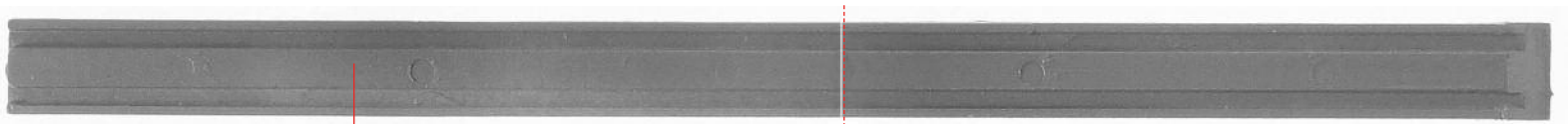

16-07

d 2 x

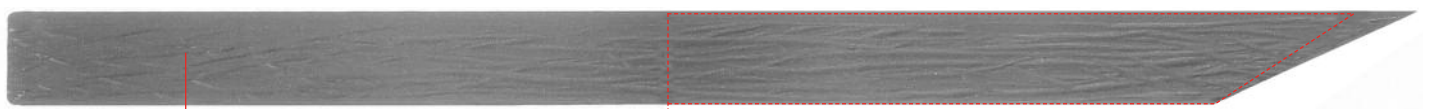

16-03

M 1:1

d

d

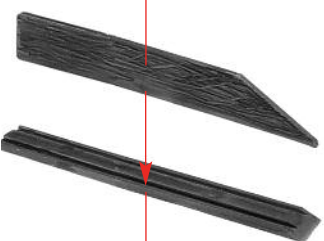

e

c

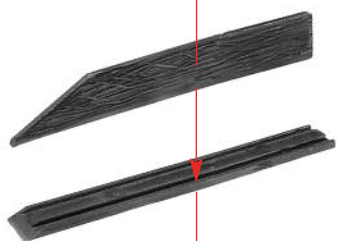

f

c

g 2 x



16-05

16-06



15-03

h

Colorierungsvorschlag, schwarz
Colouring proposal, black
Proposition de coloration, noir
Kleurenvoorstel, zwart



17-01

i

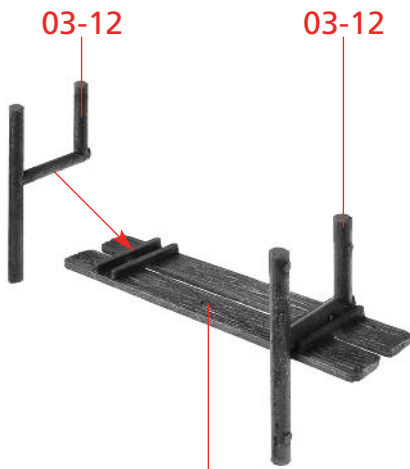

03-12

03-12

03-07

j



03-08

j

k



67

l

n

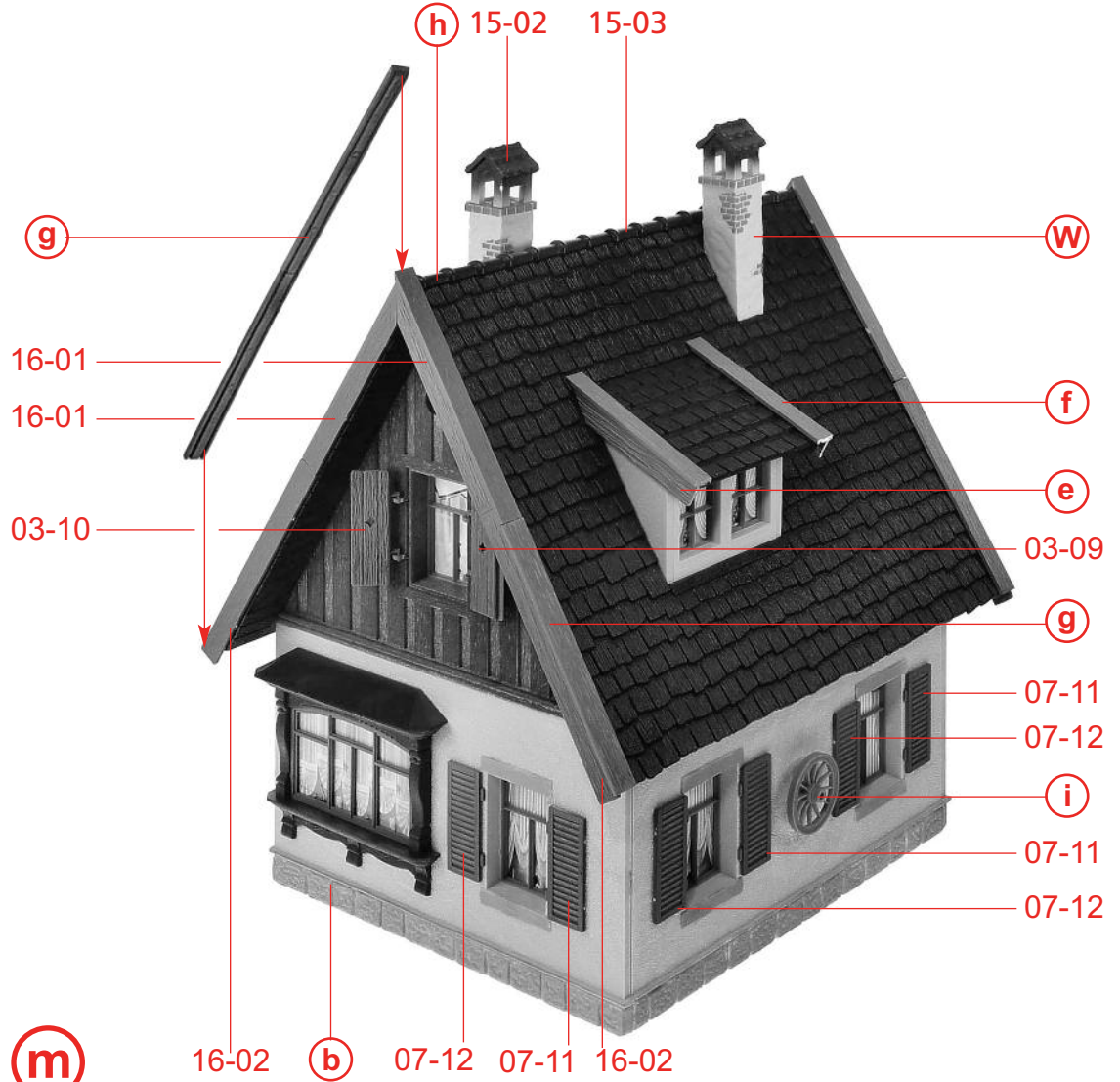

m

l

n



k

m

